



**Franklin Electric**

# AD SERIES 50 HZ

4" SUBMERSIBLE PUMP FOR DEEP WELLS





## 4" SUBMERSIBLE PUMP

Application .....	4
Family Curve.....	5
Model Numbering.....	5
Cross Section Drawing and Parts List .....	6
<b>1AD.....</b>	<b>8</b>
Performance Curve.....	8
Dimensions.....	9
<b>2AD.....</b>	<b>10</b>
Performance Curve.....	10
Dimensions.....	11
<b>3AD.....</b>	<b>12</b>
Performance Curve.....	12
Dimensions.....	13
<b>4AD.....</b>	<b>14</b>
Performance Curve.....	14
Dimensions.....	15
<b>5AD.....</b>	<b>16</b>
Performance Curve.....	16
Dimensions.....	17
<b>6AD.....</b>	<b>18</b>
Performance Curve.....	18
Dimensions.....	19
<b>8AD.....</b>	<b>20</b>
Performance Curve.....	20
Dimensions.....	21
<b>12AD.....</b>	<b>22</b>
Performance Curve.....	22
Dimensions.....	23
<b>16AD.....</b>	<b>24</b>
Performance Curve.....	24
Dimensions.....	25

## AD SERIES

The 4" AD Series submersible pumps features high efficiency floating impeller system and excellent resistance against wear when operating in abrasive and sandy well condition.

### APPLICATIONS

- Municipal water works
- Water distribution and pressure boosting
- Irrigation and sprinkler systems
- Water supply to and from tanks, reservoir and wells
- Residential and farm wells and drainage
- General industry

### FEATURES

- Compact, reliable and suited to operate in horizontal position
- Built-in check valve to protect the pump against water hammer risk
- Floating impellers to grant a better performance and longer life for the pump against abrasion
- The hydraulic design is such to enhance the overall efficiency thus reducing energy consumption and making the pumping systems more cost effective

### PUMP SPECIFICATION

- Flow: up to 24 m<sup>3</sup>/h at 50 Hz
- Head: up to 306 m at 50 Hz
- Motor Power: from 0.37 kW to 7.5 kW
- Water temperature range: up to 50 °C
- Maximum allowable amount of sand: 100 g/m<sup>3</sup>
- Outlet diameter: 1 1/4" for 1AD-2AD-3AD-4AD-5AD  
2" for 6AD-8AD-12AD-16AD
- Maximum pump diameter (including cable guard): 97.5 mm
- Rotation: counter clockwise when looking into the discharge
- Pump can work continuously in vertical or horizontal position

### MOTOR SPECIFICATION

- Motor adapter in compliance with NEMA standard
- For more information consult the product catalog of Submersible motors

### AVAILABLE ON REQUEST

- Cooling shroud
- 1 1/2" Outlet diameter for 2AD-3AD-4AD-5AD up on request

# SUBMERSIBLE PUMPS



## FAMILY CURVE

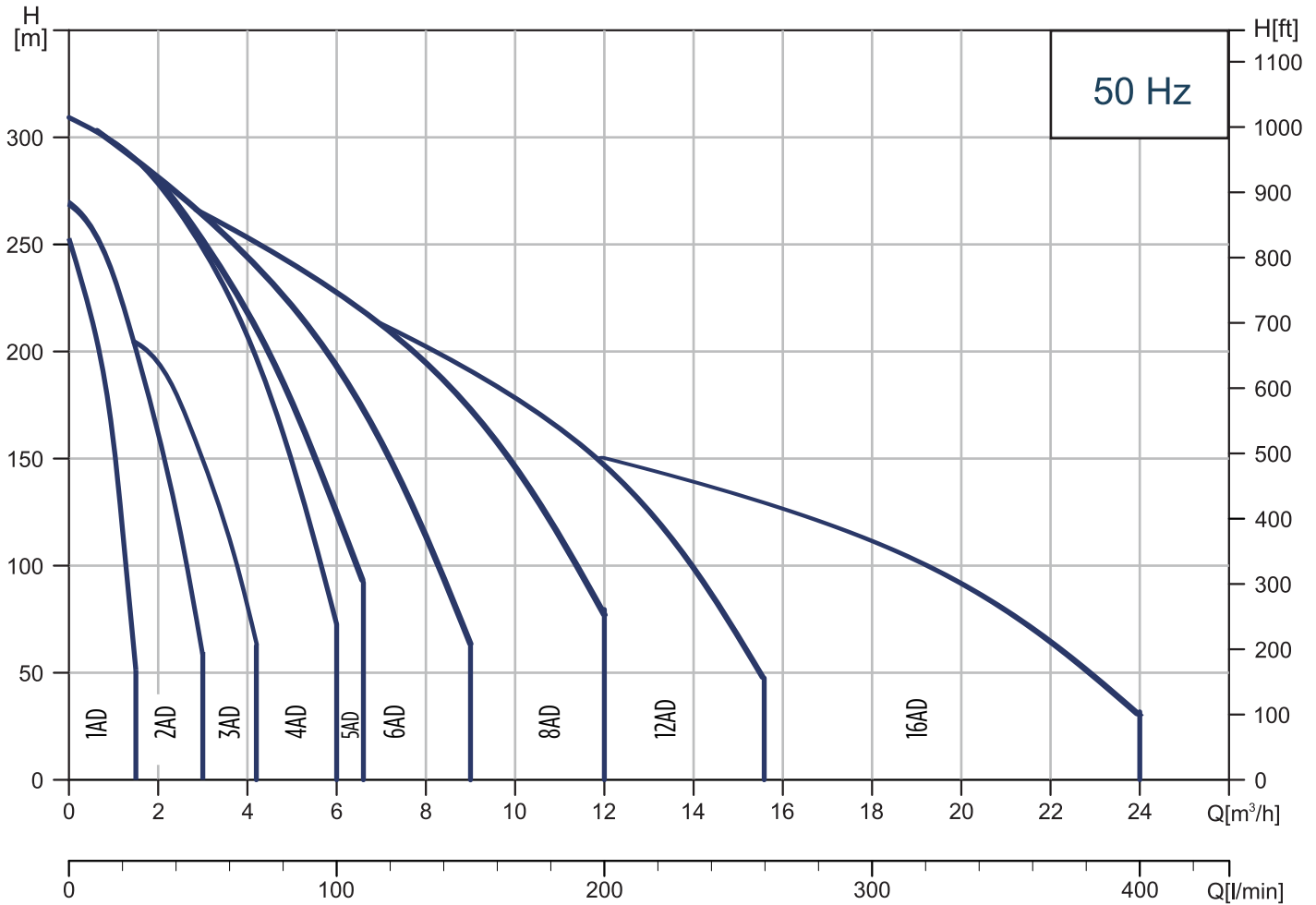

## MODEL NOMENCLATURE

4 AD 7-10

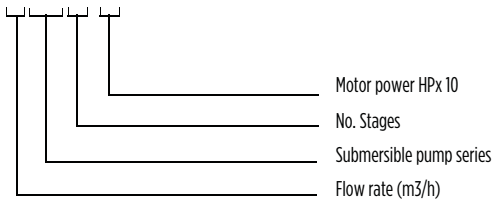

**Examples:** 4AD7-10

4 = Nominal flow 4 m³/hr, AD = AD Series, 7 = 7 Stages, 10 = Motor power 1.0hp

## 1AD - 2AD - 3AD - 4AD - 5AD SERIES PUMP SECTION AND LIST OF MAIN COMPONENTS

Ref. N.	Description	Material
1	Motor Adapter	Casted Stainless Steel
2	Bowl	Stainless Steel
3	Impeller	Glass Filled Noryl
4	Diffuser	Glass Filled Polycarbonate
5	Sleeve / Casing	Stainless Steel
6	Thrust Washer	Stainless Steel
7	Shaft Bushing	Stainless Steel
8	Intermediate Bearing	N. B. R.
9	Top Diffuser	Glass Filled Polycarbonate
10	Discharge Head	Casted Stainless Steel
11	Non Return Valve	Stainless Steel
12	Cable Guard	Stainless Steel
13	Intermediate Shaft Bushing	Stainless Steel
14	Shaft	Stainless Steel
15	Coupling	Stainless Steel
16	Filter	Stainless Steel

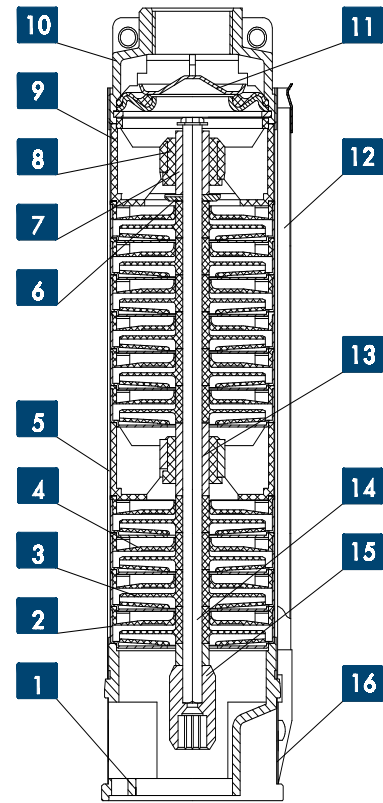

## 6AD - 8AD SERIES PUMP SECTION AND LIST OF MAIN COMPONENTS

Ref. N.	Description	Material
1	Motor Adapter	Casted Stainless Steel
2	Bowl	Stainless Steel
3	Impeller	Glass Filled Noryl
4	Diffuser	Glass Filled Polycarbonate
5	Sleeve / Casing	Stainless Steel
6	Thrust Washer	Stainless Steel
7	Shaft Bushing	Stainless Steel
8	Intermediate Bearing	N. B. R.
9	Top Diffuser	Glass Filled Polycarbonate
10	Discharge Head	Casted Stainless Steel
11	Non Return Valve	Stainless Steel
12	Cable Guard	Stainless Steel
13	Intermediate Shaft Bushing	Stainless Steel
14	Shaft	Stainless Steel
15	Coupling	Stainless Steel
16	Filter	Stainless Steel

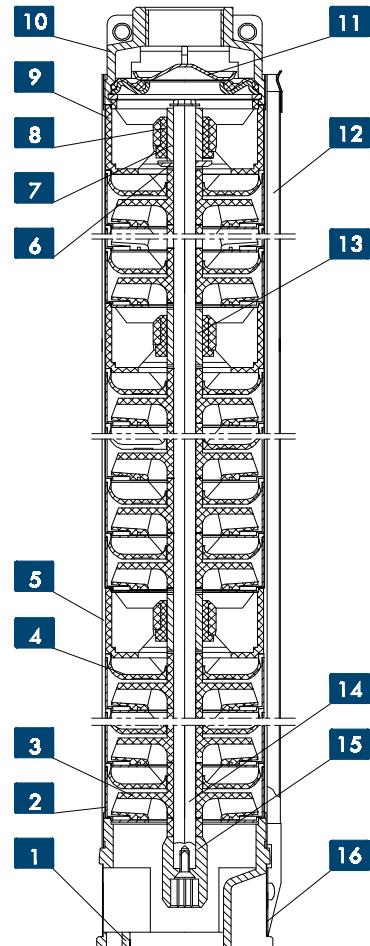

## 12AD - 16AD SERIES PUMP SECTION AND LIST OF MAIN COMPONENTS

Ref. N.	Description	Material
1	Motor Adapter	Casted Stainless Steel
2	Bowl	Stainless Steel
3	Impeller	Glass Filled Noryl
4	Diffuser	Glass Filled Polycarbonate
5	Sleeve / Casing	Stainless Steel
6	Thrust Washer	Stainless Steel
7	Shaft Bushing	Stainless Steel
8	Intermediate Bearing	N. B. R.
9	Top Diffuser	Glass Filled Polycarbonate
10	Discharge Head	Casted Stainless Steel
11	Non Return Valve	Stainless Steel
12	Cable Guard	Stainless Steel
13	Intermediate Shaft Bushing	Stainless Steel
14	Shaft	Stainless Steel
15	Coupling	Stainless Steel
16	Filter	Stainless Steel

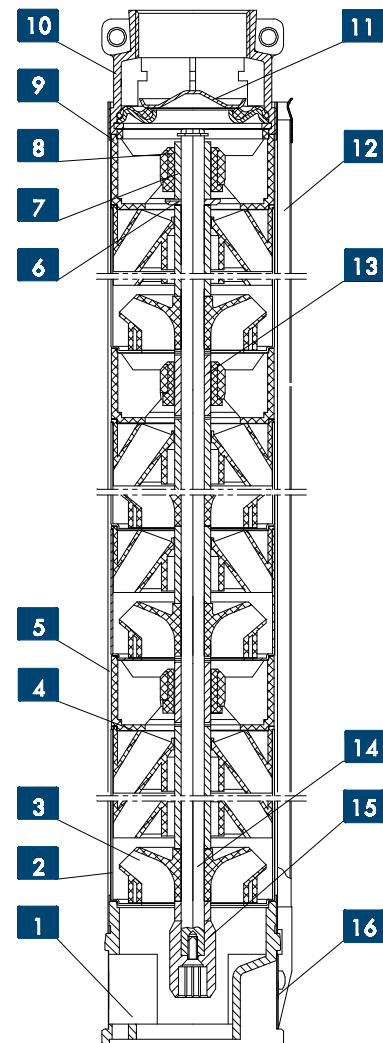

# SUBMERSIBLE PUMPS

## 1AD

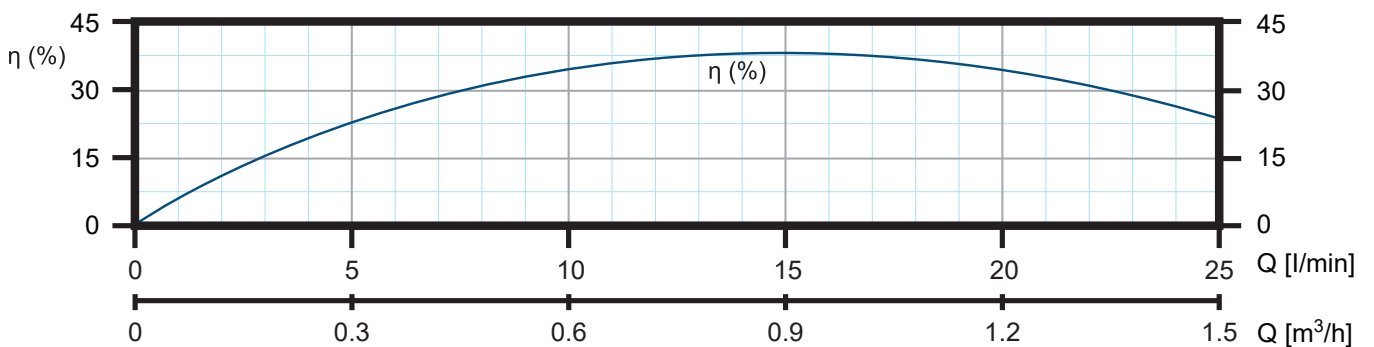
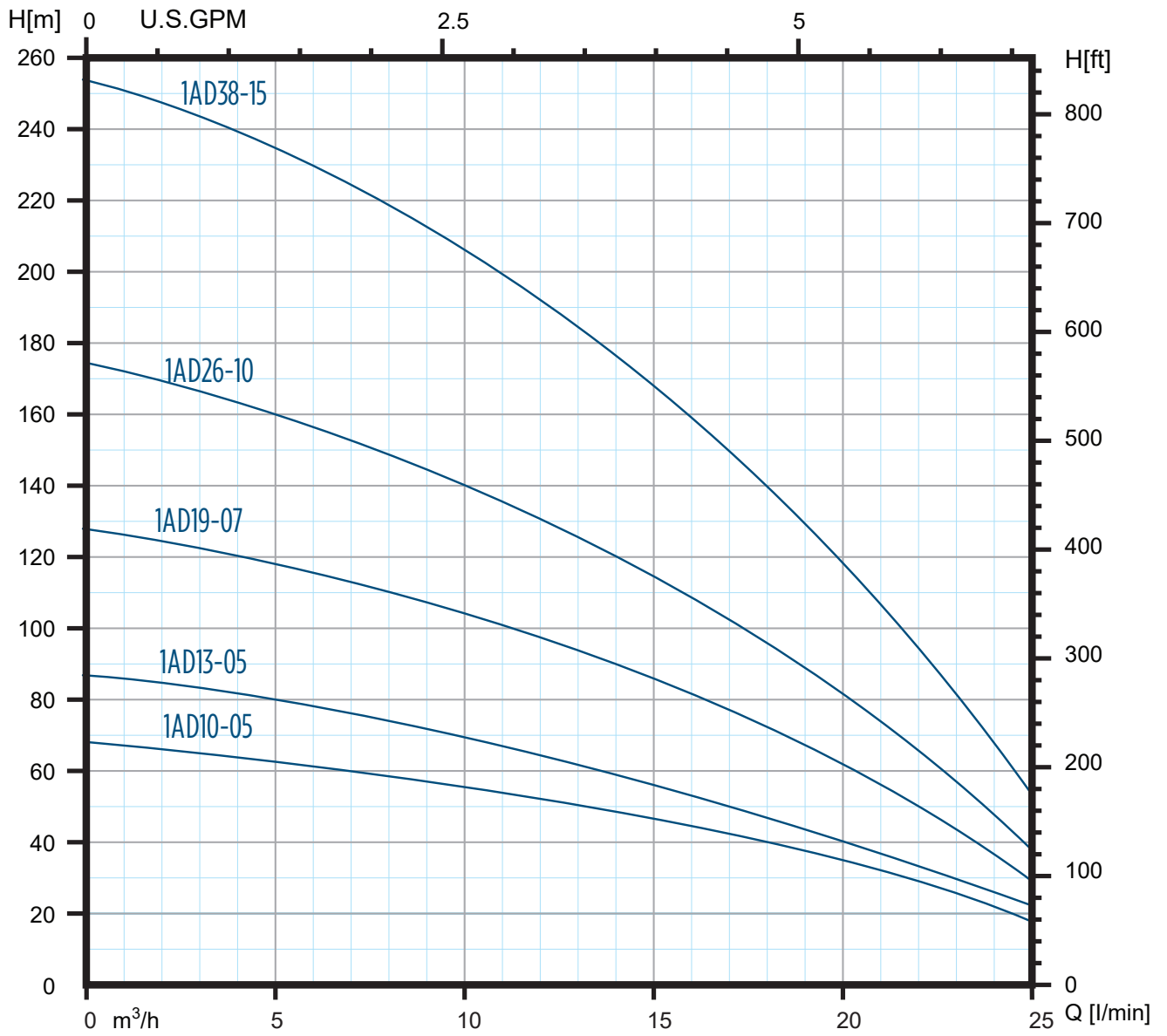

The hydraulic characteristics are guaranteed, according to ISO standard 9906:2012, grade 3B

# SUBMERSIBLE PUMPS

## 1AD - PERFORMANCE

PUMP TYPE	STAGES	MOTOR		DELIVERY						
		kW	HP	M <sup>3</sup> /hr	0	0.3	0.6	0.9	1.2	1.5
				LPM	0	5	10	15	20	25
1AD10-05	10	0.37	0.55	HEAD (m)	67	63	55	46	33	18
1AD13-05	13	0.37	0.55		86	78	70	56	42	23
1AD19-07	19	0.55	0.75		126	118	105	86	60	30
1AD26-10	26	0.75	1.0		173	160	141	117	81	39
1AD38-15	38	1.1	1.5		253	234	208	169	117	52

## 1AD - DIMENSIONS

PUMP TYPE	DISCHARGE (DN)	SINGLE PHASE						THREE PHASE					
		DIMENSIONS (mm)			WEIGHT (kg)			DIMENSIONS (mm)			WEIGHT (kg)		
		A	B	C	P.E.	MOTOR	P.M.A.	A	B	C	P.E.	MOTOR	P.M.A.
1AD10-05	1.5"	346	242	588	3	8.6	11.6	346	242	588	3	8.2	11.2
1AD13-05	1.5"	400	242	642	3.5	8.6	12.1	400	242	642	3.5	8.2	11.7
1AD19-07	1.5"	505	270	775	4.7	9.5	14.2	505	270	775	4.7	9.5	14.2
1AD26-10	1.5"	657	298	955	6.3	10.9	17.2	657	298	955	6.3	10.9	17.2
1AD38-15	1.5"	866	345	1211	8.3	12.7	21	866	298	1164	8.3	10.9	19.2

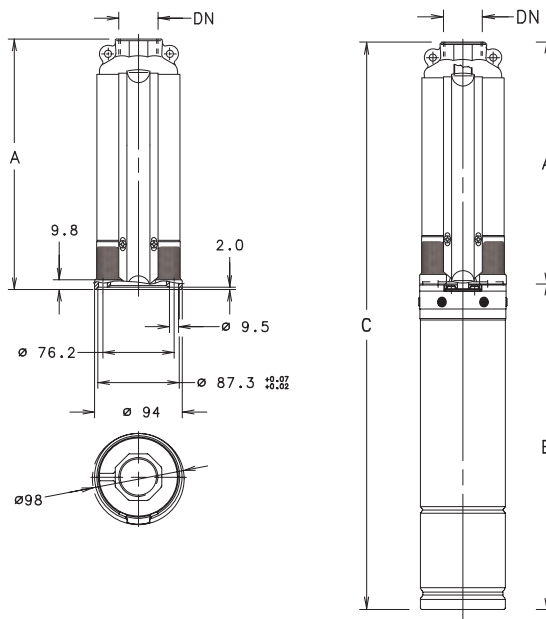

# SUBMERSIBLE PUMPS



## 2AD

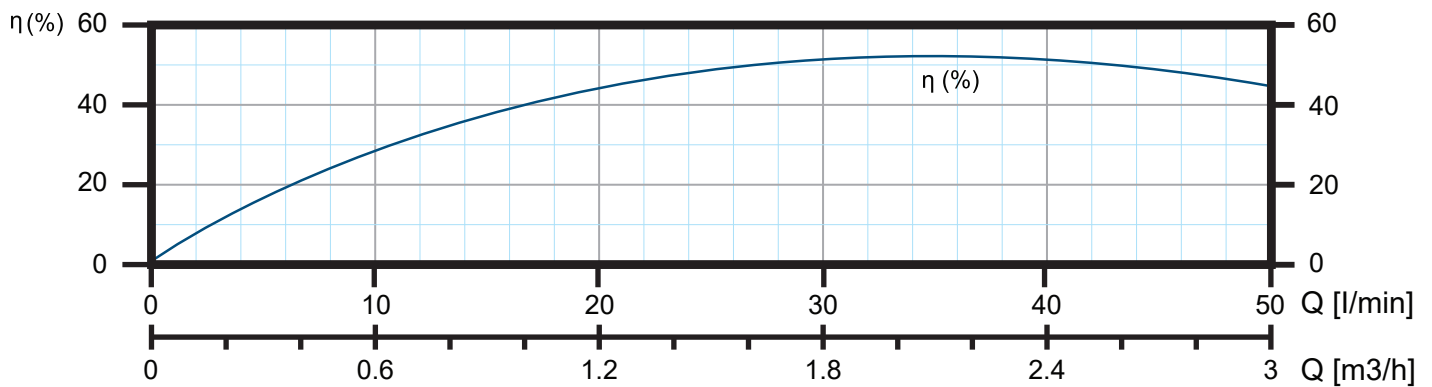
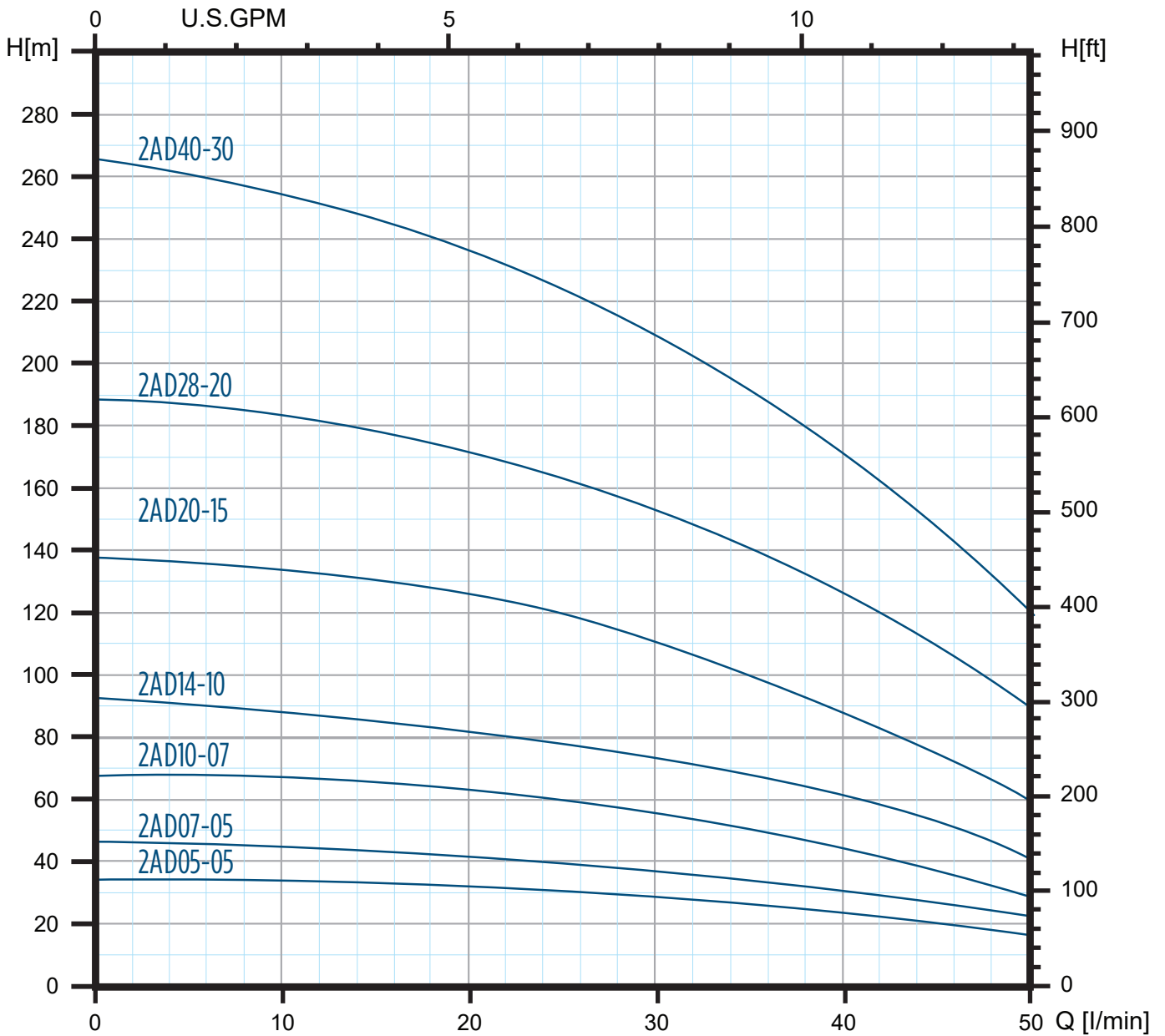

The hydraulic characteristics are guaranteed, according to ISO standard 9906:2012, grade 3B

# SUBMERSIBLE PUMPS

## 2AD - PERFORMANCE

PUMP TYPE	STAGES	MOTOR		DELIVERY							
		kW	HP	M <sup>3</sup> /hr	0	1.5	1.8	2.1	2.4	2.7	3.0
				LPM	0	25	30	35	40	45	50
2AD05-05	5	0.37	0.55	HEAD (m)	33	28	26	24	20	17	13
2AD07-05	7	0.37	0.55		47	39	35	32	28	24	19
2AD10-07	10	0.55	0.75		67	56	52	47	41	36	27
2AD14-10	14	0.75	1.0		93	78	73	66	57	50	37
2AD20-15	20	1.1	1.5		133	113	104	97	82	72	53
2AD28-20	28	1.5	2.0		187	158	146	130	115	97	74
2AD40-30	40	2.2	3.0		267	226	208	186	164	136	106

## 2AD - DIMENSIONS

PUMP TYPE	DISCHARGE (DN)	SINGLE PHASE						THREE PHASE					
		DIMENSIONS (mm)			WEIGHT (kg)			DIMENSIONS (mm)			WEIGHT (kg)		
		A	B	C	P.E.	MOTOR	P.M.A.	A	B	C	P.E.	MOTOR	P.M.A.
2AD05-05	1.5"	259	242	501	2	8.6	10.6	259	242	501	2	8.2	10.2
2AD07-05	1.5"	295	242	537	2.5	8.6	11.1	295	242	537	2.5	8.2	10.7
2AD10-07	1.5"	347	270	617	3	9.5	12.5	347	270	617	3	9.5	12.5
2AD14-10	1.5"	416	298	714	4.3	10.9	15.2	416	298	714	4.3	10.9	15.2
2AD20-15	1.5"	521	345	866	4.8	12.7	17.5	521	298	819	4.8	10.9	15.7
2AD28-20	1.5"	700	384	1084	6.4	15	21.4	700	345	1045	6.4	12.7	19.1
2AD40-30	1.5"	899	484	1383	8.5	18.6	27.1	899	513	1412	8.5	20	28.5

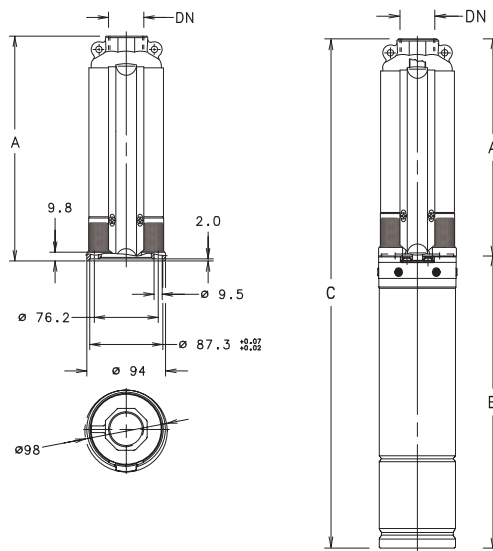

# SUBMERSIBLE PUMPS



## 3AD

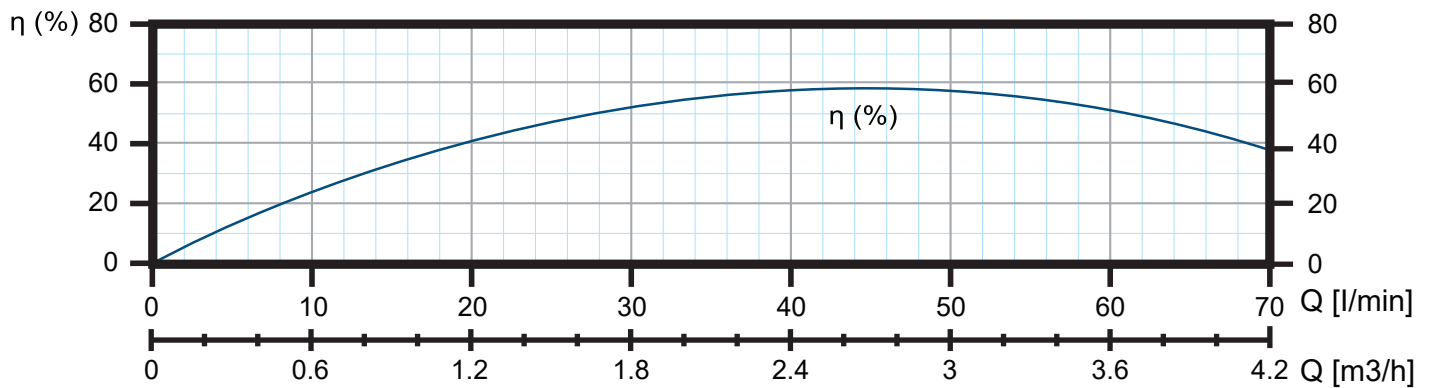
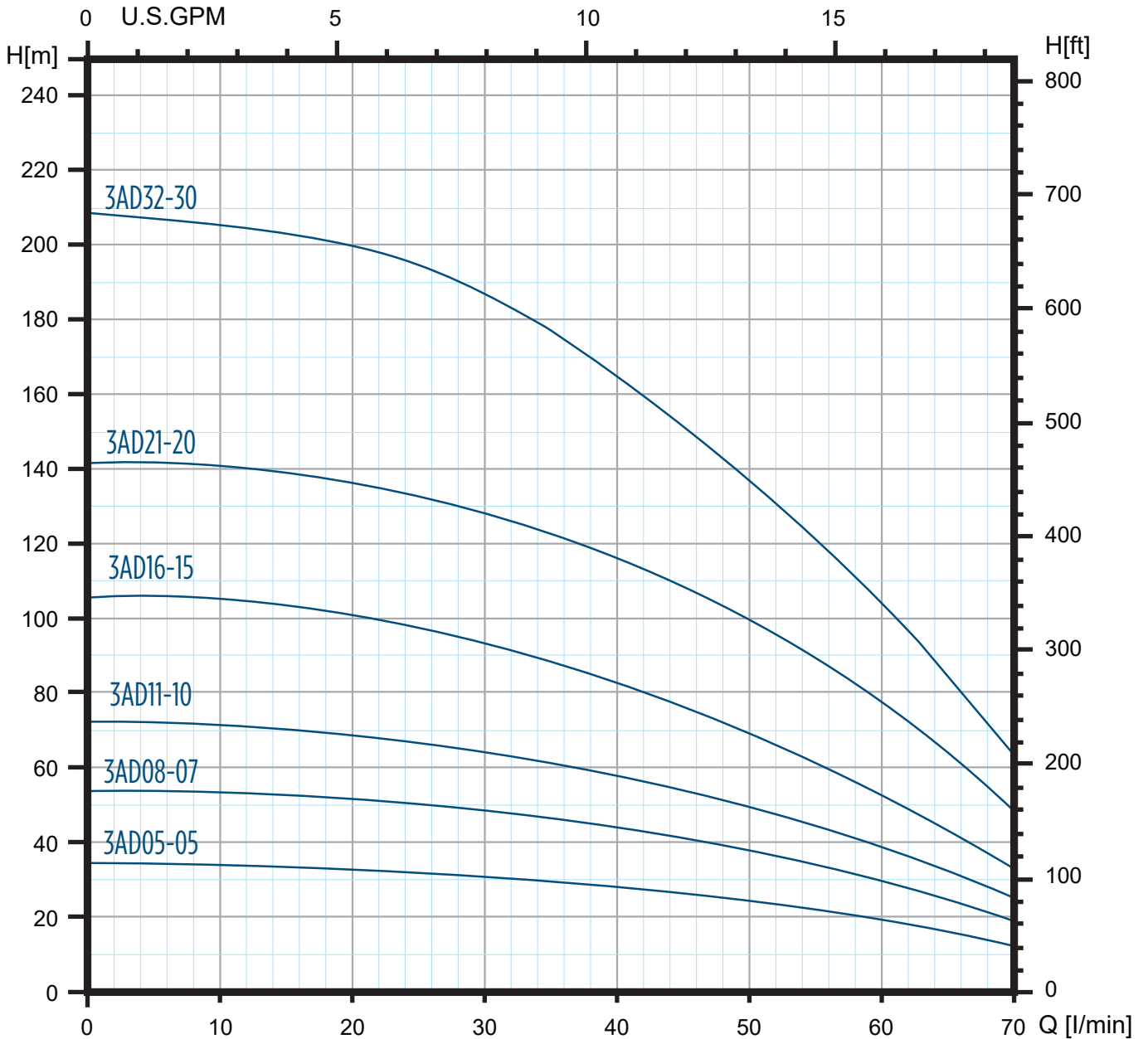

The hydraulic characteristics are guaranteed, according to ISO standard 9906:2012, grade 3B

# SUBMERSIBLE PUMPS

## 3AD - PERFORMANCE

PUMP TYPE	STAGES	MOTOR		DELIVERY							
		kW	HP	M <sup>3</sup> /hr	0	2.1	2.4	2.7	3.0	3.6	4.2
				LPM	0	35	40	45	50	60	70
3AD05-05	5	0.37	0.55	HEAD (m)	34	29	27	25	23	18	12
3AD08-07	8	0.55	0.75		54	46	43	41	38	30	19
3AD11-10	11	0.75	1.0		72	61	58	54	49	38	28
3AD16-15	16	1.1	1.5		106	89	83	77	70	54	34
3AD21-20	21	1.5	2.0		142	122	115	108	100	79	49
3AD32-30	32	2.2	3.0		208	177	165	152	138	104	64

## 3AD - DIMENSIONS

PUMP TYPE	DISCHARGE (DN)	SINGLE PHASE						THREE PHASE					
		DIMENSIONS (mm)			WEIGHT (kg)			DIMENSIONS (mm)			WEIGHT (kg)		
		A	B	C	P.E.	MOTOR	P.M.A.	A	B	C	P.E.	MOTOR	P.M.A.
3AD05-05	1.5"	259	242	501	2.1	8.6	10.7	259	242	501	2.1	8.2	10.3
3AD08-07	1.5"	312	270	582	2.6	9.5	12.1	312	270	582	2.6	9.5	12.1
3AD11-10	1.5"	364	298	662	3.2	10.9	14.1	364	298	662	3.2	10.9	14.1
3AD16-15	1.5"	451	345	796	4.1	12.7	16.8	451	298	749	4.1	10.9	15
3AD21-20	1.5"	538	384	922	5	15	20	538	345	883	5	12.7	17.7
3AD32-30	1.5"	759	484	1243	7.1	18.6	25.7	759	513	1272	7.1	20	27.1

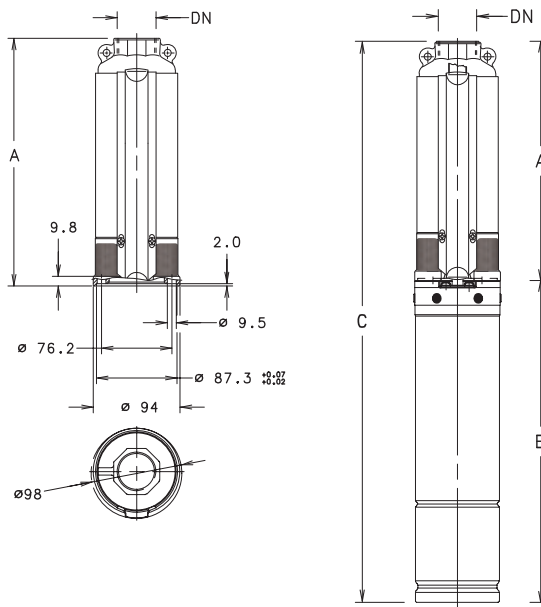

# SUBMERSIBLE PUMPS



## 4AD

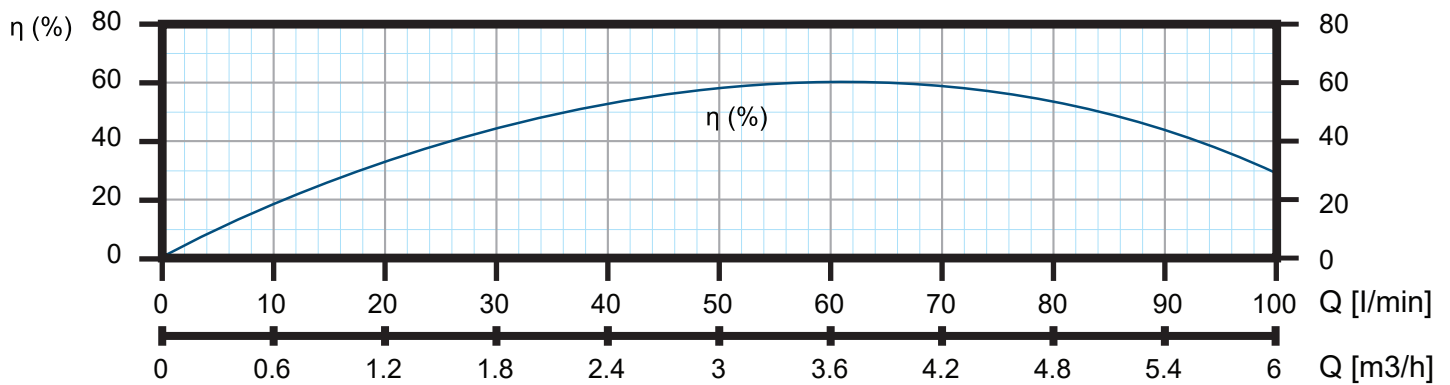
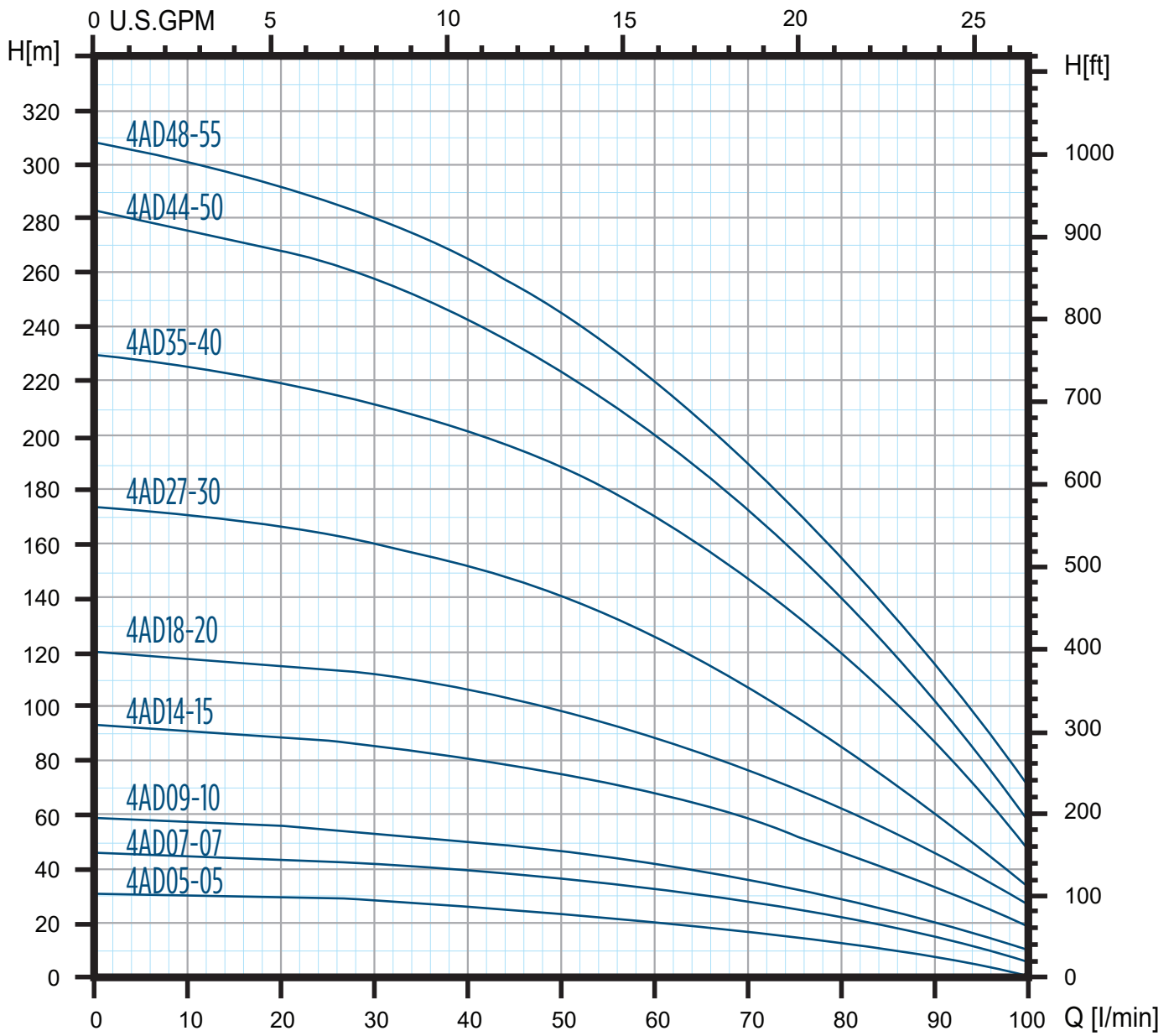

The hydraulic characteristics are guaranteed, according to ISO standard 9906:2012, grade 3B

# SUBMERSIBLE PUMPS

## 4AD - PERFORMANCE

PUMP TYPE	STAGES	MOTOR		DELIVERY							
		kW	HP	M <sup>3</sup> /hr	0	3.0	3.6	4.2	4.8	5.4	6.0
				LPM	0	50	60	70	80	90	100
4AD05-05	5	0.37	0.55	HEAD (m)	33	22	21	17	13	8	3
4AD07-07	7	0.55	0.75		46	36	33	28	21	13	7
4AD09-10	9	0.75	1.0		59	47	43	37	28	20	10
4AD14-15	14	1.1	1.5		93	76	68	58	47	33	19
4AD18-20	18	1.5	2.0		120	98	88	77	62	47	27
4AD27-30	27	2.2	3.0		175	141	127	109	87	61	35
4AD35-40	35	3.0	4.0		231	184	166	119	119	85	49
4AD44-50	44	3.7	5.0		285	223	201	139	139	99	55
4AD48-55	48	4.0	5.5		322	245	228	160	160	118	70

## 4AD - DIMENSIONS

PUMP TYPE	DISCHARGE (DN)	SINGLE PHASE						THREE PHASE					
		DIMENSIONS (mm)			WEIGHT (kg)			DIMENSIONS (mm)			WEIGHT (kg)		
		A	B	C	P.E.	MOTOR	P.M.A.	A	B	C	P.E.	MOTOR	P.M.A.
4AD05-05	1.5"	276	242	518	2.3	8.6	10.9	276	242	518	2.3	8.2	10.5
4AD07-07	1.5"	318	270	588	2.6	9.5	12.1	318	270	588	2.6	9.5	12.1
4AD09-10	1.5"	361	298	659	3.1	10.9	14	361	298	659	3.1	10.9	14
4AD14-15	1.5"	464	345	809	4.2	12.7	16.9	464	298	762	4.2	10.9	15.1
4AD18-20	1.5"	545	384	929	5	15	20	545	345	890	5	12.7	17.7
4AD27-30	1.5"	762	484	1246	7.2	18.6	25.8	762	513	1275	7.2	20	27.2
4AD35-40	1.5"	927	741	1668	8.7	32.2	40.9	927	589	1516	8.7	25.4	34.1
4AD44-50	1.5"	-	-	-	-	-	-	1297	652	1949	10.7	28.6	39.3
4AD48-55	1.5"	-	-	-	-	-	-	1380	741	2121	11.4	32.2	43.6

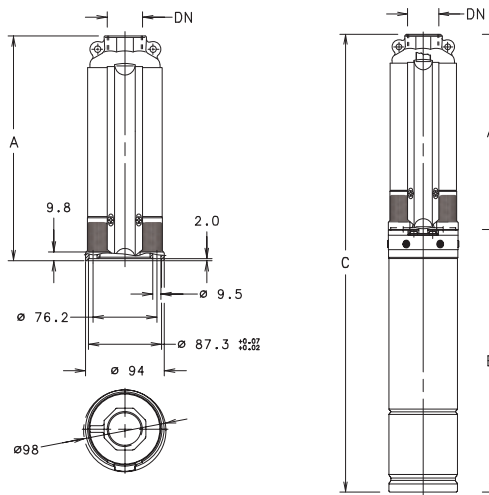

# SUBMERSIBLE PUMPS



## 5AD

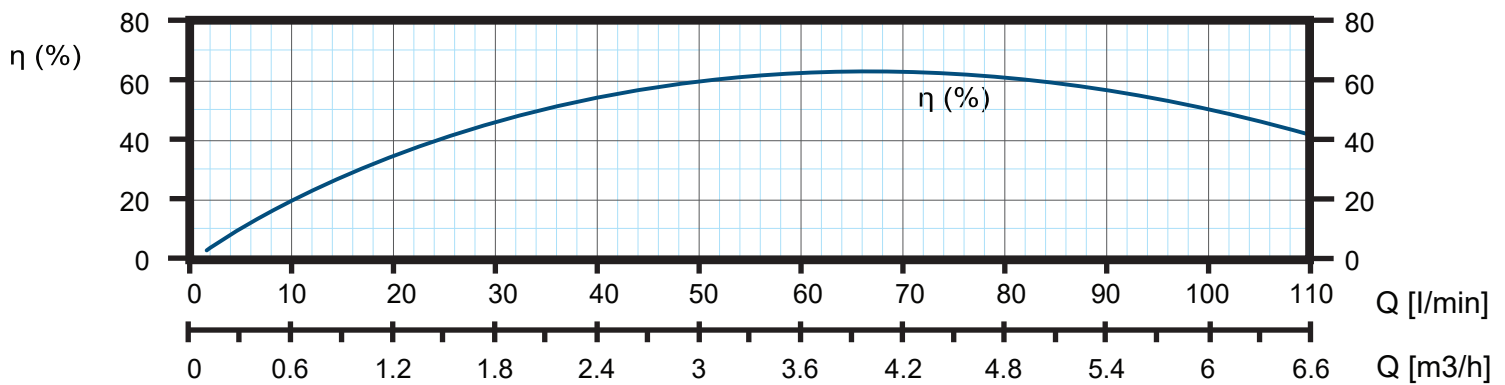
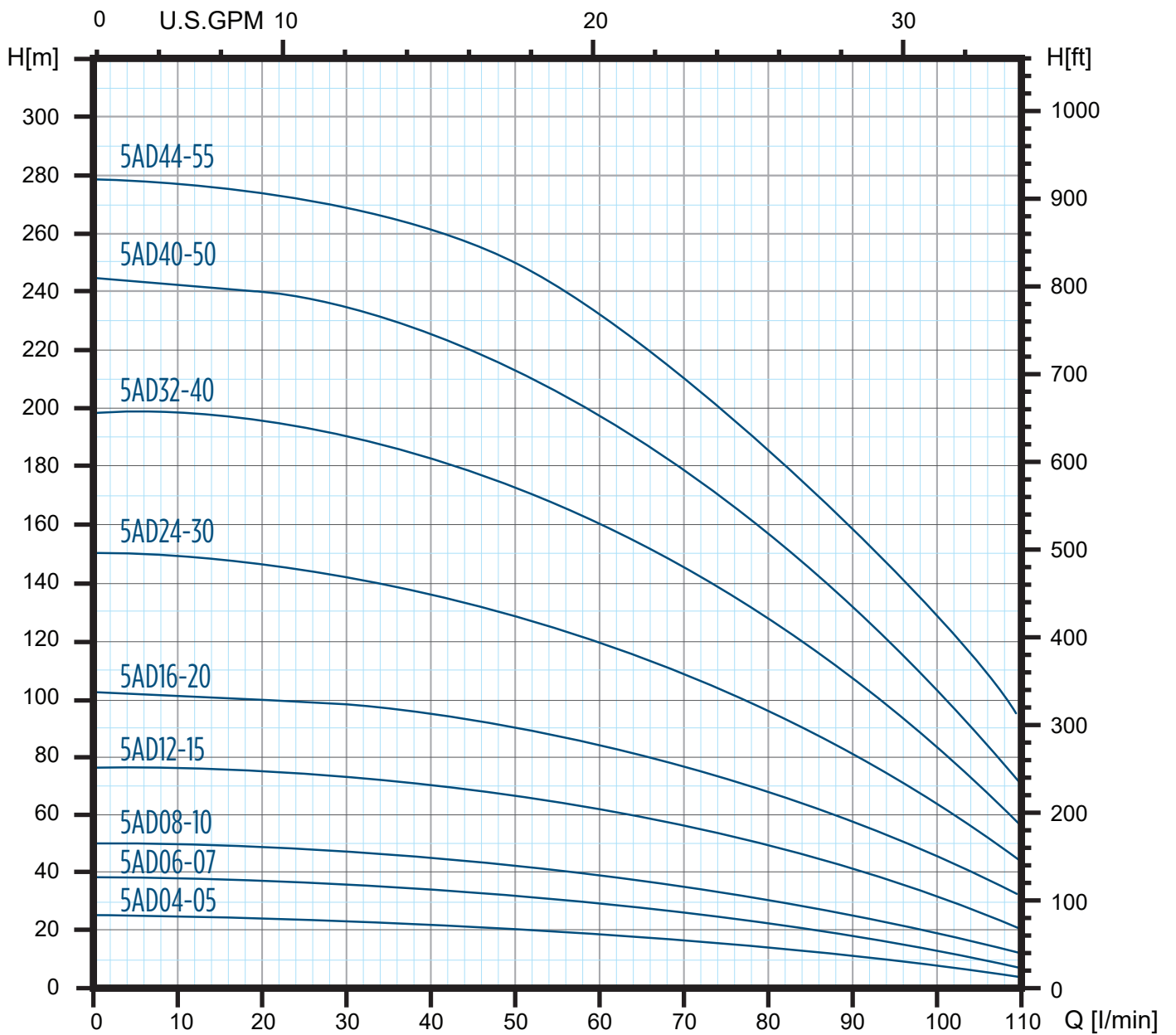

The hydraulic characteristics are guaranteed, according to ISO standard 9906:2012, grade 3B

# SUBMERSIBLE PUMPS

## 5AD - PERFORMANCE

PUMP TYPE	STAGES	MOTOR		DELIVERY							
		KW	HP	M <sup>3</sup> /hr	0	3.6	4.2	4.8	5.4	6.0	6.6
				LPM	0	60	70	80	90	100	110
5AD04-05	4	0.37	0.55	HEAD (m)	26	19	17	14	11	7	4
5AD06-07	6	0.55	0.75		38	30	26	22	18	12	8
5AD08-10	8	0.75	1.0		51	39	35	30	24	18	14
5AD12-15	12	1.1	1.5		77	63	57	49	41	31	21
5AD16-20	16	1.5	2.0		102	86	77	68	57	46	34
5AD24-30	24	2.2	3.0		151	122	111	97	80	62	44
5AD32-40	32	3.0	4.0		203	162	146	127	105	80	59
5AD40-50	40	3.7	5.0		253	202	182	159	131	102	70
5AD44-55	44	4.0	5.5		278	230	210	187	159	127	94

## 5AD - DIMENSIONS

PUMP TYPE	DISCHARGE (DN)	SINGLE PHASE						THREE PHASE					
		DIMENSIONS (mm)			WEIGHT (kg)			DIMENSIONS (mm)			WEIGHT (kg)		
		A	B	C	P.E.	MOTOR	P.M.A.	A	B	C	P.E.	MOTOR	P.M.A.
5AD04-05	1.5"	270	242	512	2.2	8.6	10.8	270	242	512	2.2	8.2	10.4
5AD06-07	1.5"	318	270	588	2.5	9.5	12	318	270	588	2.5	9.5	12
5AD08-10	1.5"	366	298	664	3	10.9	13.9	366	298	664	3	10.9	13.9
5AD12-15	1.5"	463	345	808	3.8	12.7	16.5	463	298	761	3.8	10.9	14.7
5AD16-20	1.5"	559	384	943	4.8	15	19.8	559	345	904	4.8	12.7	17.5
5AD24-30	1.5"	753	484	1237	6.6	18.6	25.2	753	513	1266	6.6	20	26.6
5AD32-40	1.5"	977	741	1718	8.9	32.2	41.1	977	589	1566	8.9	25.4	34.3
5AD40-50	1.5"	-	-	-	-	-	-	1170	652	1822	10.3	28.6	38.9
5AD44-55	1.5"	-	-	-	-	-	-	1267	741	2008	11.3	32.2	43.5

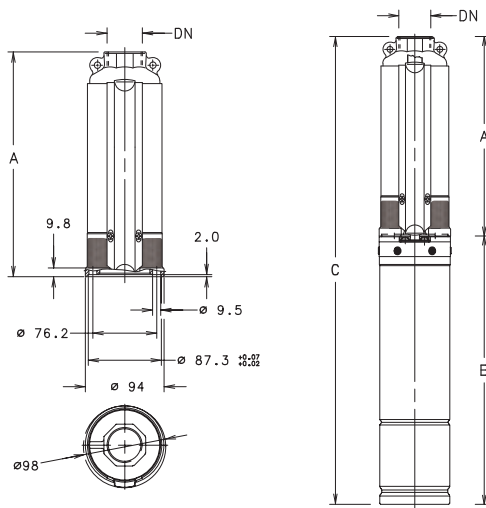

# SUBMERSIBLE PUMPS



## 6AD

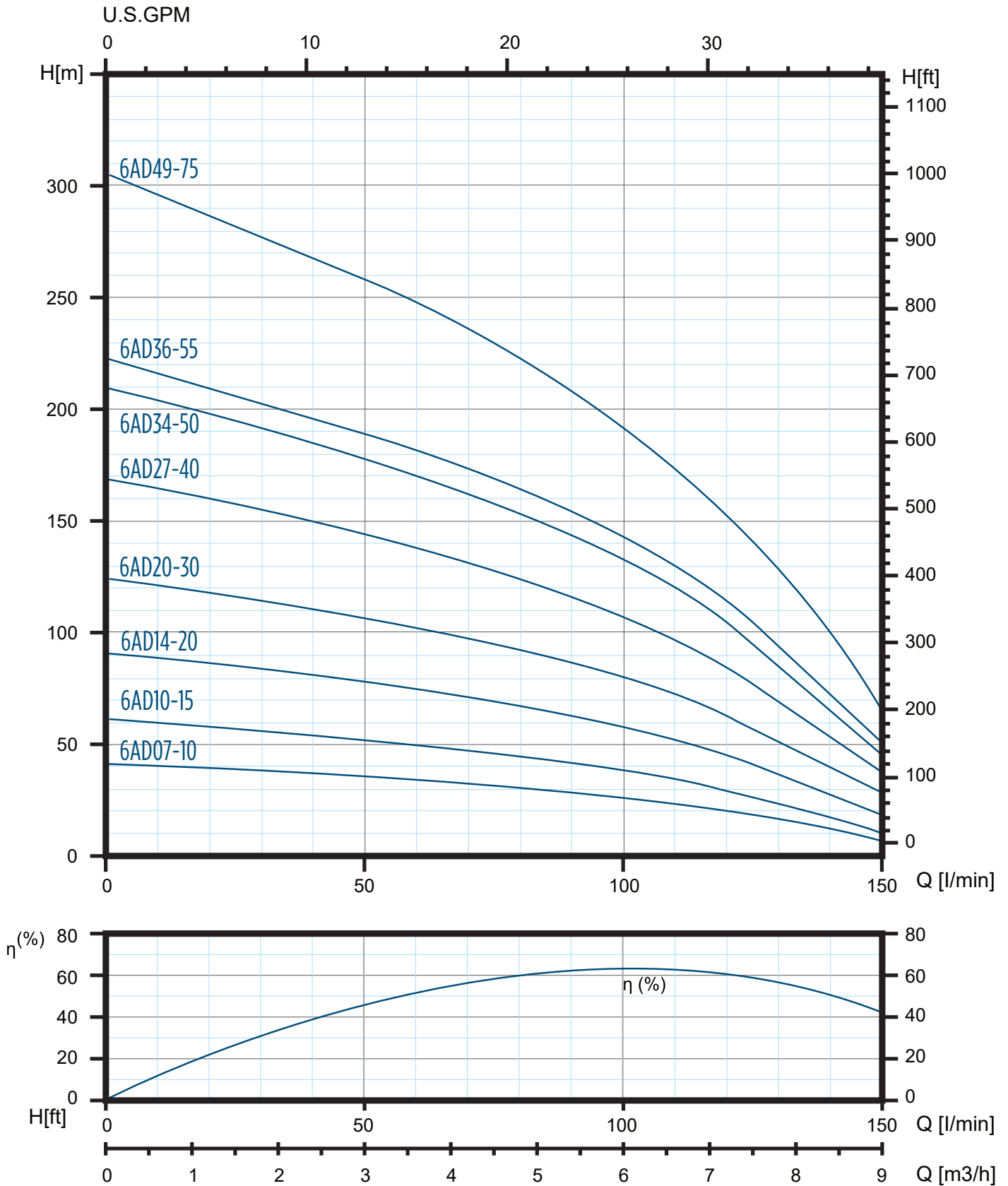

The hydraulic characteristics are guaranteed, according to ISO standard 9906:2012, grade 3B

# SUBMERSIBLE PUMPS

## 6AD - PERFORMANCE

PUMP TYPE	STAGES	MOTOR		DELIVERY							
		kW	HP	M <sup>3</sup> /hr	0	5.4	6.0	6.6	7.2	7.8	9.0
				LPM	0	90	100	110	120	130	150
6AD07-10	7	0.75	1.0	HEAD (m)	42	28	25	22	19	15	8
6AD10-15	10	1.1	1.5		62	41	38	34	29	23	12
6AD14-20	14	1.5	2.0		90	63	59	53	46	37	19
6AD20-30	20	2.2	3.0		125	86	80	71	62	52	29
6AD27-40	27	3.0	4.0		169	115	107	96	84	70	39
6AD34-50	34	3.7	5.0		208	143	132	120	103	86	48
6AD36-55	36	4.0	5.5		221	154	143	127	112	93	49
6AD49-75	49	5.5	7.5		302	209	193	171	151	123	64

## 6AD - DIMENSIONS

PUMP TYPE	DISCHARGE (DN)	SINGLE PHASE						THREE PHASE					
		DIMENSIONS (mm)			WEIGHT (kg)			DIMENSIONS (mm)			WEIGHT (kg)		
		A	B	C	P.E.	MOTOR	P.M.A.	A	B	C	P.E.	MOTOR	P.M.A.
6AD07-10	2"	387	298	685	3.2	10.9	14.1	387	298	685	3.2	10.9	14.1
6AD10-15	2"	481	345	826	4	12.7	16.7	481	298	779	4	10.9	14.9
6AD14-20	2"	604	384	988	5.3	15	20.3	604	345	949	5.3	12.7	18
6AD20-30	2"	791	484	1275	7.2	18.6	25.8	791	513	1304	7.2	20	27.2
6AD27-40	2"	1036	741	1777	9.2	32.2	41.4	1036	589	1625	9.2	25.4	34.6
6AD34-50	2"	-	-	-	-	-	-	1253	589	1842	11.3	25.4	36.7
6AD36-55	2"	-	-	-	-	-	-	1345	652	1997	12.5	28.6	41.1
6AD49-75	2"	-	-	-	-	-	-	1747	741	2488	16	32.2	48.2

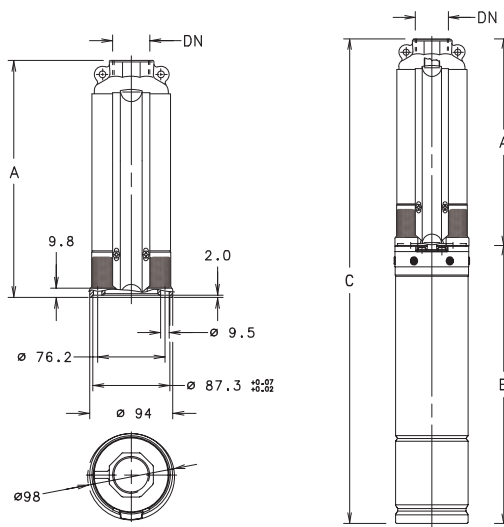

# SUBMERSIBLE PUMPS



## 8AD

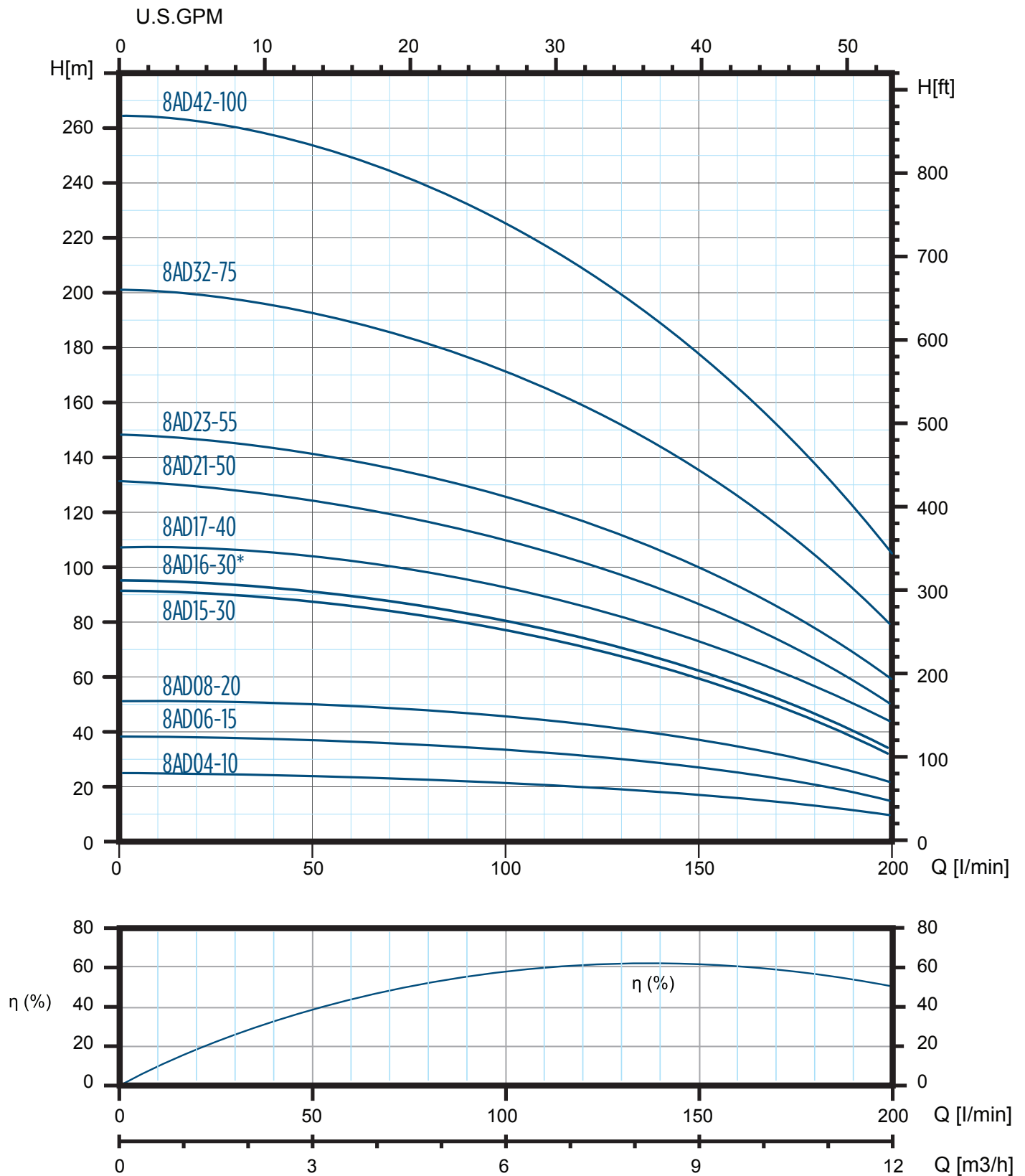

The hydraulic characteristics are guaranteed, according to ISO standard 9906:2012, grade 3B

# SUBMERSIBLE PUMPS

## 8AD - PERFORMANCE

PUMP TYPE	STAGES	MOTOR		DELIVERY							
		kW	HP	M <sup>3</sup> /hr	0	7.2	7.8	8.4	9.0	9.6	12.0
				LPM	0	120	130	140	150	160	200
8AD04-10	4	0.75	1.0	HEAD (m)	26	21	20	19	19	18	11
8AD06-15	6	1.1	1.5		39	32	30	29	27	26	18
8AD08-20	8	1.5	2.0		52	43	40	39	37	35	24
8AD15-30	15	2.2	3.0		91	70	67	63	59	54	33
8AD16-30*	15	2.2	3.0		96	74	69	66	62	58	35
8AD17-40	17	3.0	4.0		108	87	83	79	75	70	47
8AD21-50	21	3.7	5.0		132	103	98	93	88	82	52
8AD23-55	23	4.0	5.5		148	118	113	108	101	95	60
8AD32-75	32	5.5	7.5		202	160	151	143	133	125	80
8AD42-100	42	7.5	10.0		265	210	198	187	174	164	105

## 8AD - DIMENSIONS

PUMP TYPE	DISCHARGE (DN)	SINGLE PHASE						THREE PHASE					
		DIMENSIONS (mm)			WEIGHT (kg)			DIMENSIONS (mm)			WEIGHT (kg)		
		A	B	C	P.E.	MOTOR	P.M.A.	A	B	C	P.E.	MOTOR	P.M.A.
8AD04-10	2"	295	298	593	2.3	10.9	13.2	295	298	593	2.3	10.9	13.2
8AD06-15	2"	358	345	703	3.1	12.7	15.8	358	298	656	3.1	10.9	14
8AD08-20	2"	421	384	805	3.6	15	18.6	421	345	766	3.6	12.7	16.3
8AD15-30	2"	635	484	1119	5.5	18.6	24.1	635	513	1148	5.5	20	25.5
8AD16-30*	2"	667	484	1151	5.8	18.6	24.4	667	513	1180	5.8	20	25.8
8AD17-40	2"	700	741	1441	6.1	32.2	38.3	700	589	1289	6.1	25.4	31.5
8AD21-50	2"	-	-	-	-	-	-	822	589	1411	7.3	25.4	32.7
8AD23-55	2"	-	-	-	-	-	-	918	652	1570	8.2	28.6	36.8
8AD32-75	2"	-	-	-	-	-	-	1199	741	1940	10.9	32.2	43.1
8AD42-100	2"	-	-	-	-	-	-	1542	817	2359	14.2	34.9	49.1

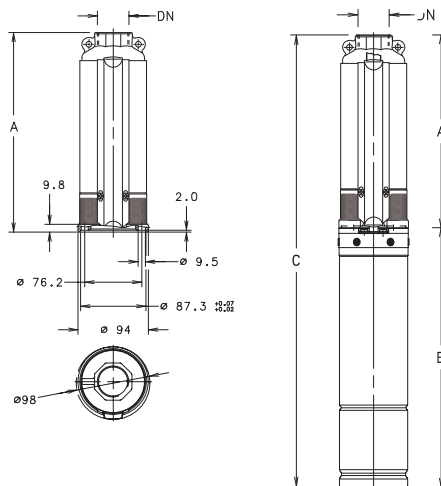

# SUBMERSIBLE PUMPS



## 12AD

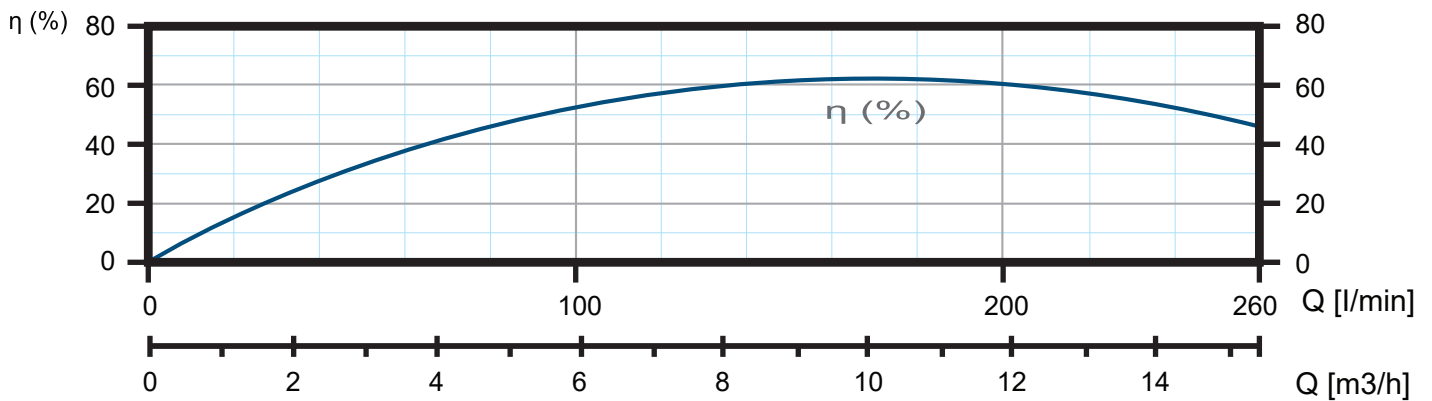
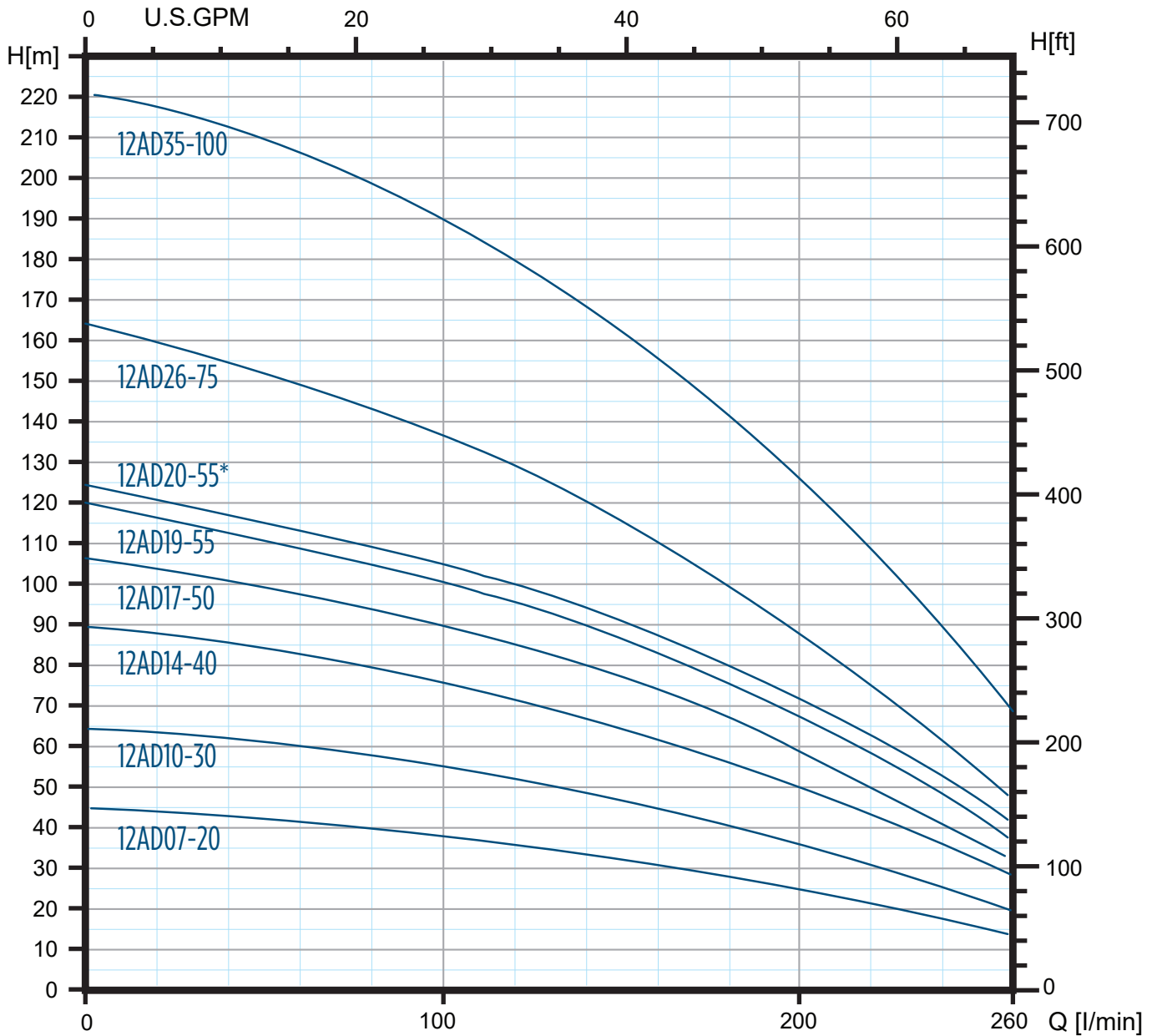

The hydraulic characteristics are guaranteed, according to ISO standard 9906:2012, grade 3B

# SUBMERSIBLE PUMPS

## 12AD - PERFORMANCE

PUMP TYPE	STAGES	MOTOR		DELIVERY							
		kW	HP	M <sup>3</sup> /hr	0	9.6	10.8	12.0	13.0	14.4	15.6
				LPM	0	160	180	200	220	240	260
12AD07-20	7	1.5	2.0	HEAD (m)	45	31	28	25	22	18	14
12AD10-30	10	2.2	3.0		64	44	41	36	32	26	20
12AD14-40	14	3.0	4.0		89	62	56	49	43	35	29
12AD17-50	17	3.7	5.0		107	74	67	59	51	42	33
12AD19-55	19	4.0	5.5		120	83	75	67	59	49	38
12AD20-55*	20	4.0	5.5		124	87	89	71	63	53	42
12AD26-75	26	5.5	7.5		163	111	100	87	75	61	47
12AD35-100	35	7.5	10.0		221	155	140	125	108	90	67

## 12AD - DIMENSIONS

PUMP TYPE	DISCHARGE (DN)	SINGLE PHASE						THREE PHASE					
		DIMENSIONS (mm)			WEIGHT (kg)			DIMENSIONS (mm)			WEIGHT (kg)		
		A	B	C	P.E.	MOTOR	P.M.A.	A	B	C	P.E.	MOTOR	P.M.A.
12AD07-20	2"	535	384	919	4.8	15	19.8	535	345	880	4.8	12.7	17.5
12AD10-30	2"	691	484	1175	6.1	18.6	24.7	691	513	1204	6.1	20	26.1
12AD14-40	2"	900	741	1641	8.1	32.2	40.3	900	589	1489	8.1	25.4	33.5
12AD17-50	2"	-	-	-	-	-	-	1085	589	1674	9.9	25.4	35.3
12AD19-55	2"	-	-	-	-	-	-	1190	652	1842	10.7	28.6	39.3
12AD20-55*	2"	-	-	-	-	-	-	1243	652	1895	11.3	28.6	39.9
12AD26-75	2"	-	-	-	-	-	-	1553	741	2294	13.4	32.2	45.6
12AD35-100	2"	-	-	-	-	-	-	2049	817	2866	17.2	34.9	52.1

\*Available upon request

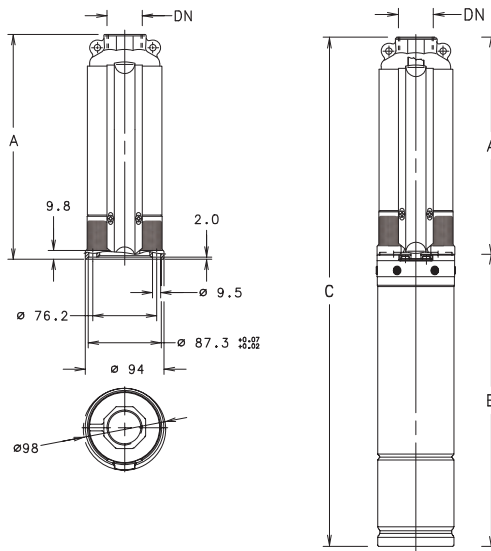

# SUBMERSIBLE PUMPS



## 16AD

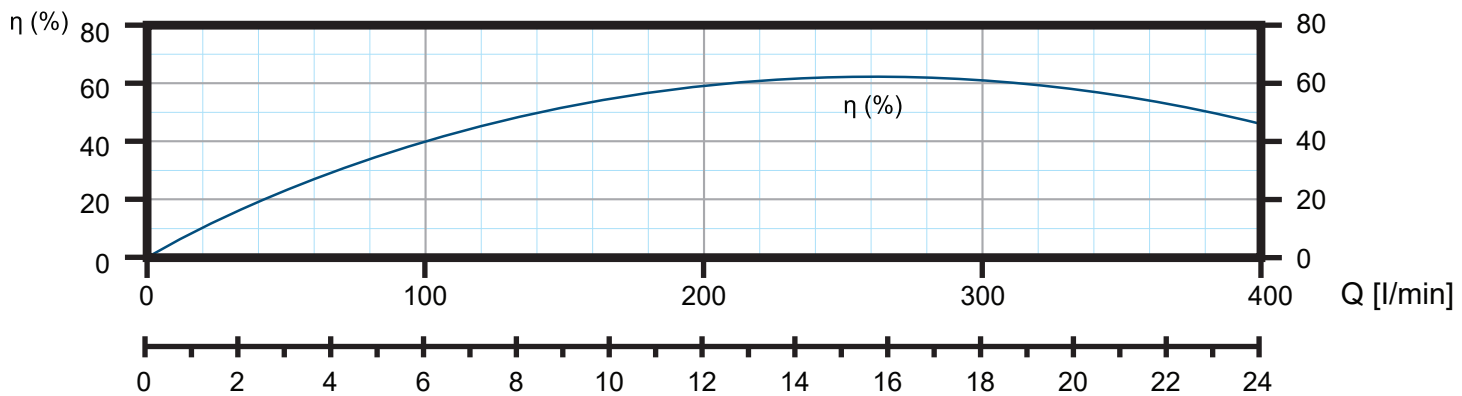
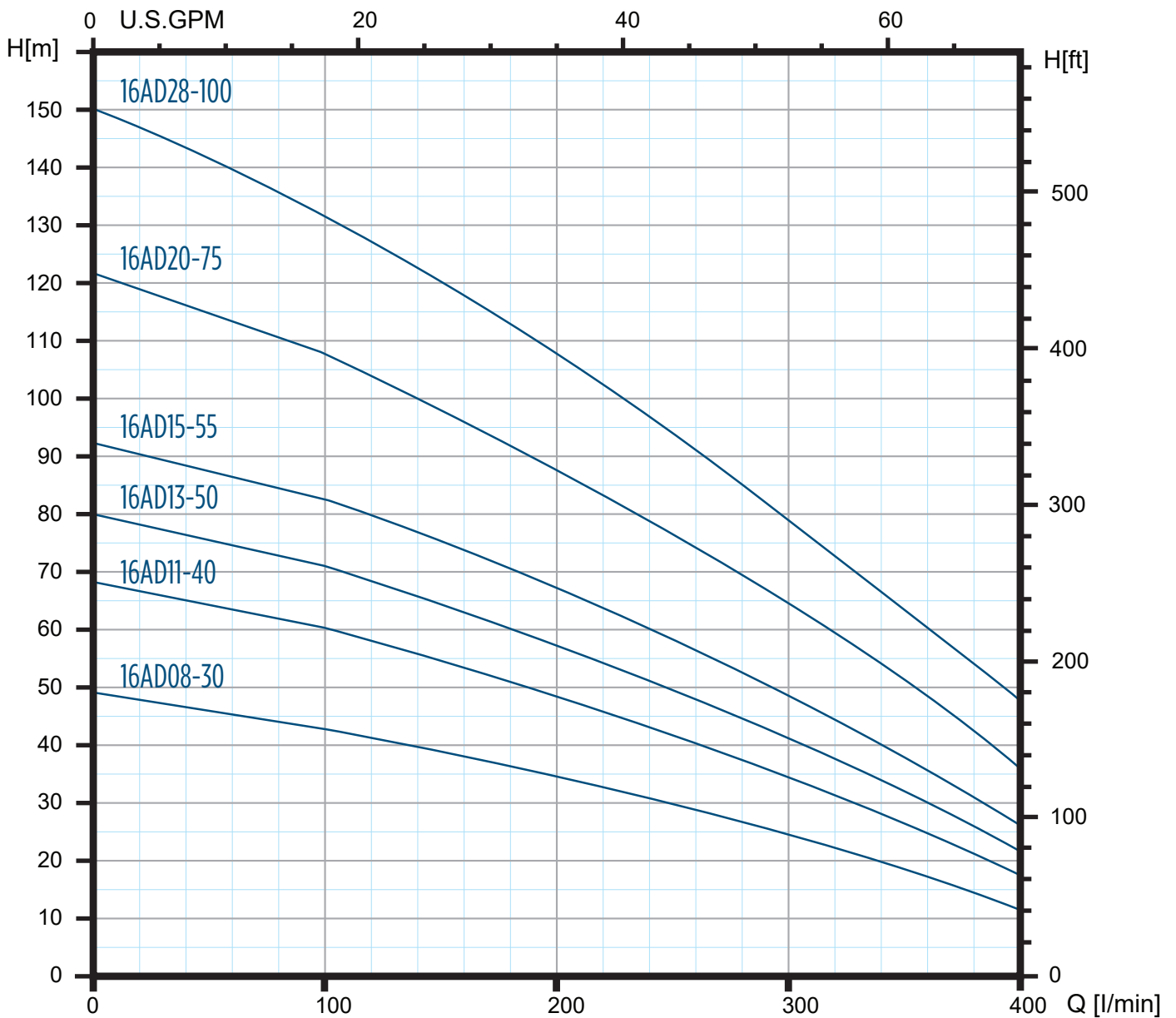

The hydraulic characteristics are guaranteed, according to ISO standard 9906:2012, grade 3B

# SUBMERSIBLE PUMPS

## 16AD - PERFORMANCE

PUMP TYPE	STAGES	MOTOR		DELIVERY							
		KW	HP	M <sup>3</sup> /hr	0	15.6	16.8	18.0	19.2	20.4	24.0
				LPM	0	260	280	300	320	340	400
16AD08-30	8	2.2	3.0	HEAD (m)	51	29	27	24	20	18	13
16AD11-40	11	3.0	4.0		70	41	38	34	30	27	18
16AD13-50	13	3.7	5.0		81	48	45	41	36	32	23
16AD15-55	15	4.0	5.5		97	58	54	50	43	39	27
16AD20-75	20	5.5	7.5		125	74	70	65	56	44	36
16AD28-100	28	7.5	10.0		151	92	85	78	70	62	48

## 16AD - DIMENSIONS

PUMP TYPE	DISCHARGE (DN)	SINGLE PHASE						THREE PHASE					
		DIMENSIONS (mm)			WEIGHT (kg)			DIMENSIONS (mm)			WEIGHT (kg)		
		A	B	C	P.E.	MOTOR	P.M.A.	A	B	C	P.E.	MOTOR	P.M.A.
16AD08-30	2"	715	484	1199	6	18.6	24.6	715	513	1228	6	20	26
16AD11-40	2"	919	741	1660	7.9	32.2	40.1	919	589	1508	7.9	25.4	33.3
16AD13-50	2"	-	-	-	-	-	-	1052	589	1641	9.1	25.4	34.5
16AD15-55	2"	-	-	-	-	-	-	1221	652	1873	10.6	28.6	39.2
16AD20-75	2"	-	-	-	-	-	-	1559	741	2300	13.3	32.2	45.5
16AD28-100	2"	-	-	-	-	-	-	2129	817	2946	18	34.9	52.9

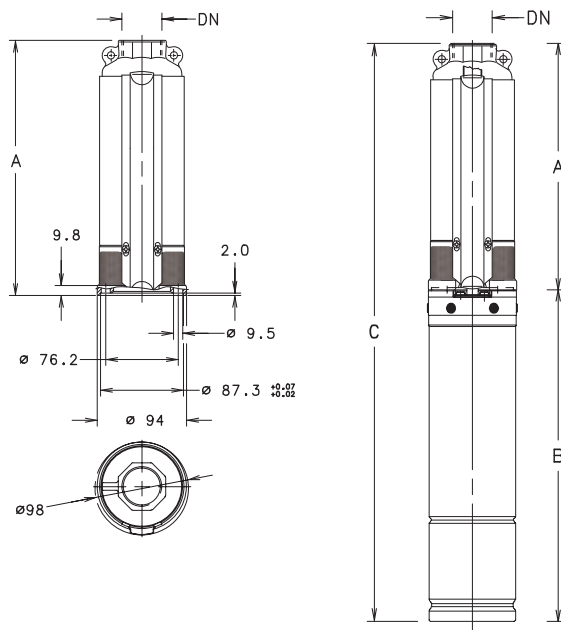



**Franklin Electric**



[www.franklinwatersea.com](http://www.franklinwatersea.com)

**ASEAN, Pakistan, Bangladesh, Sri Lanka**

Franklin Electric (SEA) Pte. Ltd | 17 Changi Business Park Central 1 | # 06-05, Honeywell Building | Singapore 486 073  
tel+65 6789 6865 | fax +65 6789 0155